

Low Noise 9V Power Supply for the Logitech Duet Squeezebox

Technical Description

By Paul Langemeijer
Document version 1.2



Table of Contents

1. Introduction.....	3
1.1 Scope.....	3
1.2 Introduction.....	3
1.3 Specifications.....	3
1.4 Circuit description.....	3
2. Measurements.....	4
3. Design.....	5
3.1 Diagram.....	5
3.2 PCB layout.....	5

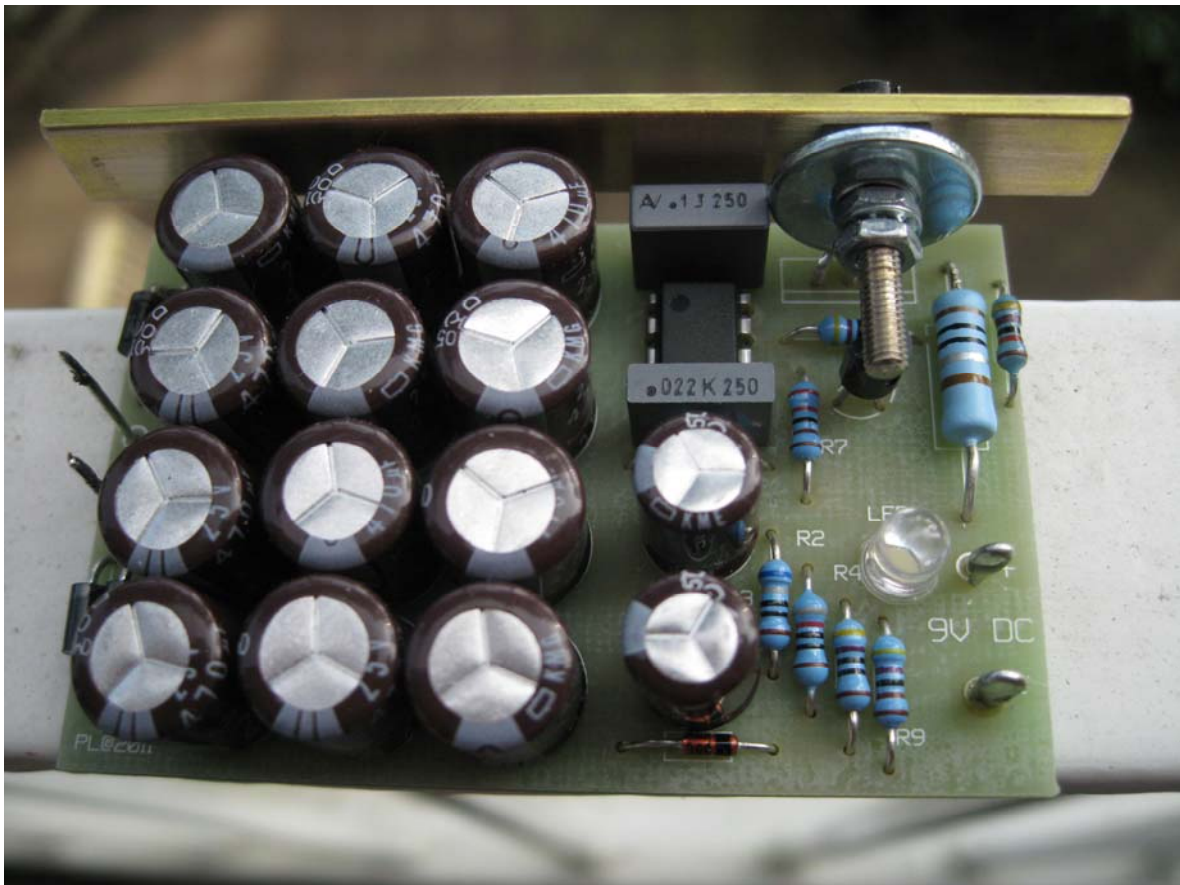

1. Introduction

1.1 Scope

This document describes the low noise 9V power supply for the Logitech Squeezebox Duet receiver.

1.2 Introduction

The supplied power supply for the Logitech Squeezebox Duet receiver is a cheap switched power supply. This type of power supply produces a lot of noise and spikes in the audio frequency range at the output. This influences the quality of the receiver in a negative way. A stable and low noise power supply, as described here, improves the sound quality of the Squeezebox receiver dramatically! You will hear more detail. The music sounds much more relaxed. You will find out that the quality of the receiver is very good. Even when the Squeezebox is connected to an external DAC, you can hear a noticeable difference.

1.3 Specifications

Designed for low noise output.

Input: 12V DC (about 1.5A)
Output: 9V DC
Maximum current: 600 mA

After switching on the power supply, it takes some seconds for the output voltage to become 9V (due to the double RC filter after the zener diode).

1.4 Circuit description

The critical parts of this power supply are:

- Low noise reference voltage. This is realized by:
 - Double RC low pass filter after the zener diode.
 - Constant current through the zener diode.
- Low noise opamp:
 - The NE5532 is an old but very good low noise audio opamp which is internally frequency compensated. No external capacitor for stabilization is required.
- Fast external power transistor circuit. The type of power transistor is not very important. However, the resistor (470 Ohm) over base-emitter is essential: it discharges the internal base-emitter capacitor and makes the transistor capable of turning-off fast. The power transistor needs some cooling (e.g. strip of aluminum).
- The printed circuit board: separate ground tracks are used.

Less critical is the buffering capacitor ($12 \times 470\mu\text{F} = 5640 \mu\text{F}$).

2. Measurements

To get an indication of the noise of the standard Logitech power supply, a measurement was done with a spectrum analyzer program on a PC (program "Align").

First a zero measurement was done to get an indication of the noise of the analog input of the PC itself.

Zero measurement (audio input PC short circuited):

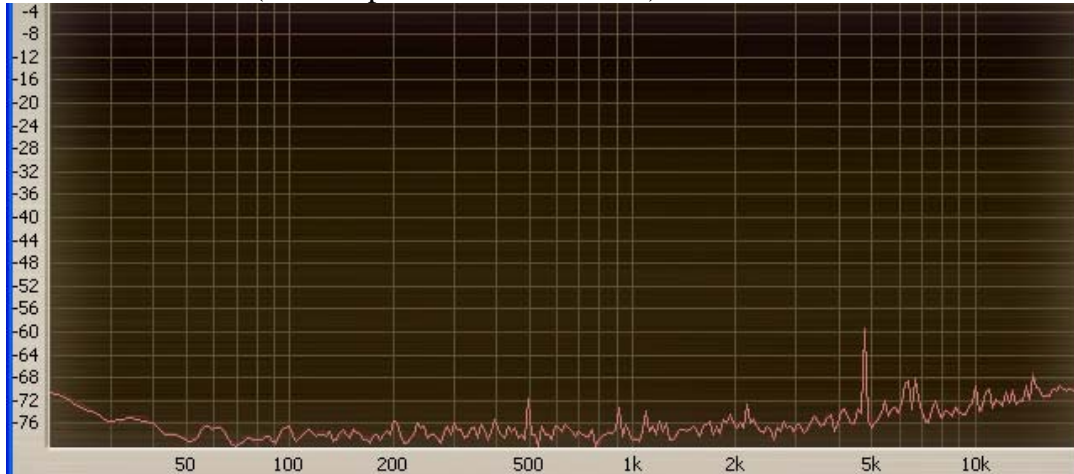

Response original Squeezebox power supply (now we understand why it is bad):

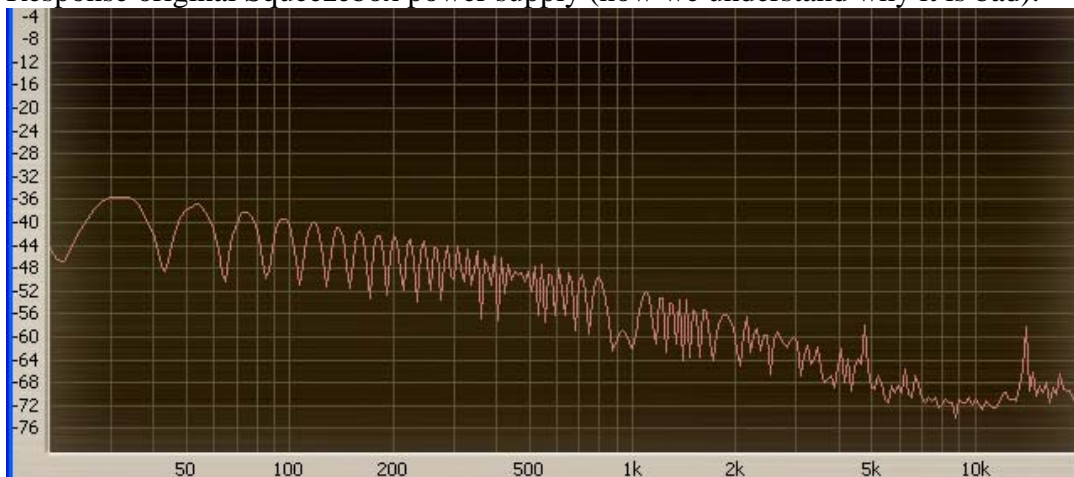

Response low noise power supply (no difference with zero measurement):

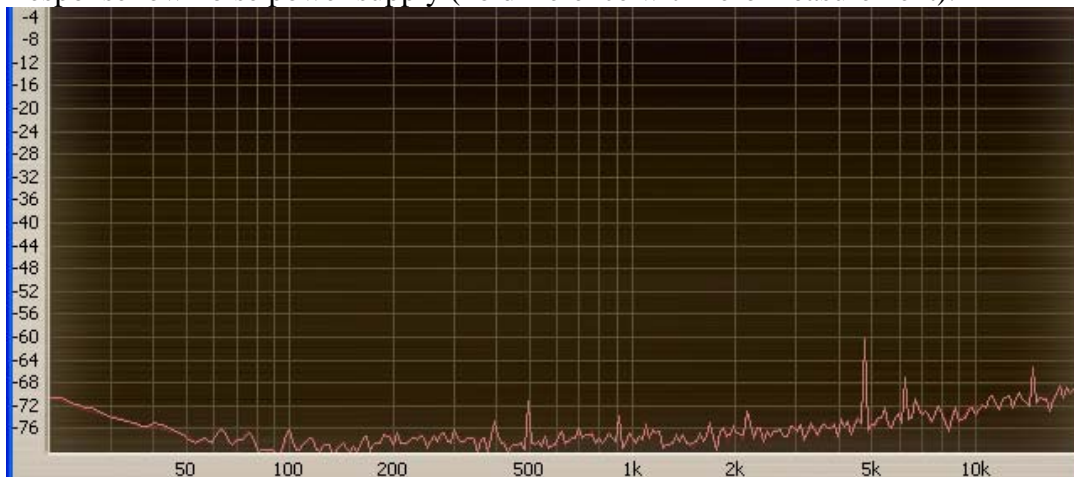

3. Design

3.1 Diagram

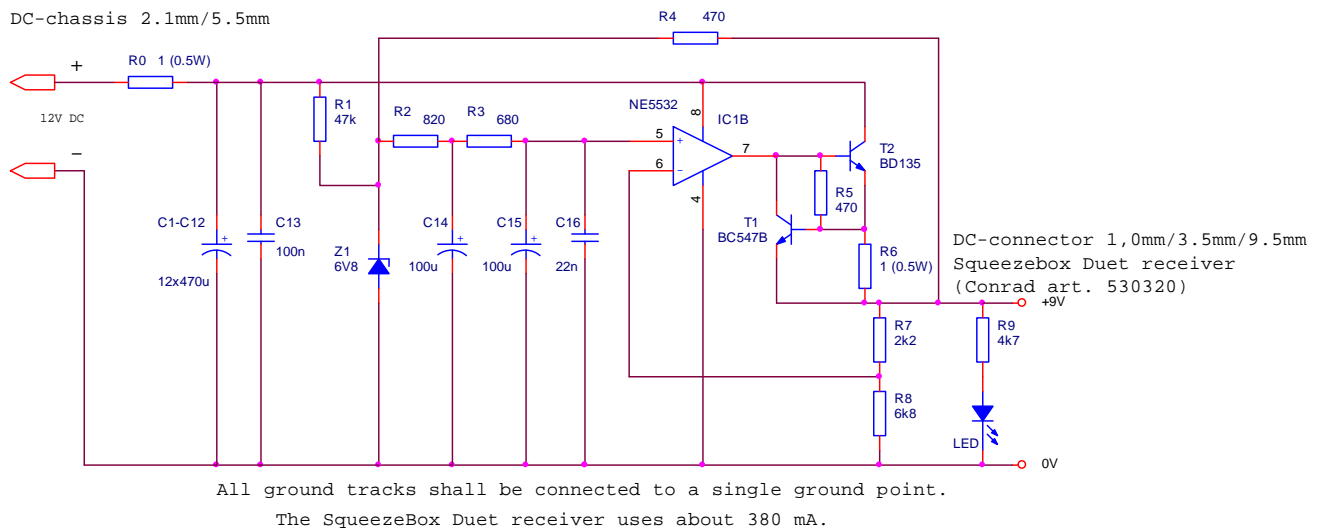

3.2 PCB layout

Print size: 6.9 x 4.5 cm

The PCB is prepared for an AC power supply of 10V (using the 4 diodes D1-D4). That means that, for a DC power supply, one diode must be replaced by a resistor of 1 Ohm and one diode must be replaced by a wire.

